

VERTICAL STRETCH WRAPPING | EDDY



**BREAK THE LIMITS,
BE UNBREAKABLE.**

Vertical machine
Machine verticale



**THE BIG
FRIEND**

Eddy is the friend you've always wanted to assist you: no-nonsense, always ready and on which you can always rely. Eddy is the stretchwrap film packaging machine with rotating arm, perfect for wrapping pallets in stretchwrap film. Its strong points are its compact overall dimensions and high performance.

Eddy, c'est l'ami que vous voudriez à vos côtés : coriace, toujours prêt à l'action et digne de confiance. Eddy est la machine à bras tournant pour banderoler des charges palettisées sous film étirable. Ses dimensions d'encombrement réduites et ses hautes performances sont ses meilleurs atouts.



TPC We improve packaging

VERTICAL STRETCH WRAPPING | EDDY

Vertical machine
Machine verticale



Large-diameter arm rotation gear.
Easy maintenance

*Couronne de rotation du bras de grand diamètre.
Entretien facile.*



The control panel with touchscreen is easy to understand using intuitive symbols.

Le panneau de commande avec écran tactile est facile à comprendre en utilisant des symboles intuitifs.

VERTICAL STRETCH WRAPPING | EDDY

Available with 3 carriage types
 Disponible avec 3 types de chariots



EB

Electromagnetic clutch
 Frein électromagnétique

MPS Motorized Pre-Stretch

Motorized pre-stretch with interchangeable pre-stretch ratios
 Pré-étirage motorisé avec ratio de pré-étirage interchangeable

MPS2 Motorized Pre-Stretch

Motorized pre-stretch with pre-stretch ratio variable with two motors
 Pré-étirage motorisé avec ratio de pré-étirage variable avec deux moteurs



Various types of top pressure units
 Types de presseur variés



Film cutting, clamping and welding system automatically adjusts to various pallet dimensions

Système de pince, coupe et soudure du film étirable autoréglable pour dimensions de palettes variées

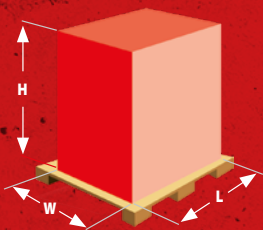

	EDDY	EDDY BIG	EDDY DOUBLE
L	1250	1800	1200
W	1250	1800	1200
H	2100	2100	2100
LS (pallet/hour)	50	40	75
HS (pallet/hour)	60	50	90
LS (pallet/hour) + TOP	30	22	60
HS (pallet/hour) + TOP	40	30	65

VERTICAL STRETCH WRAPPING | EDDY

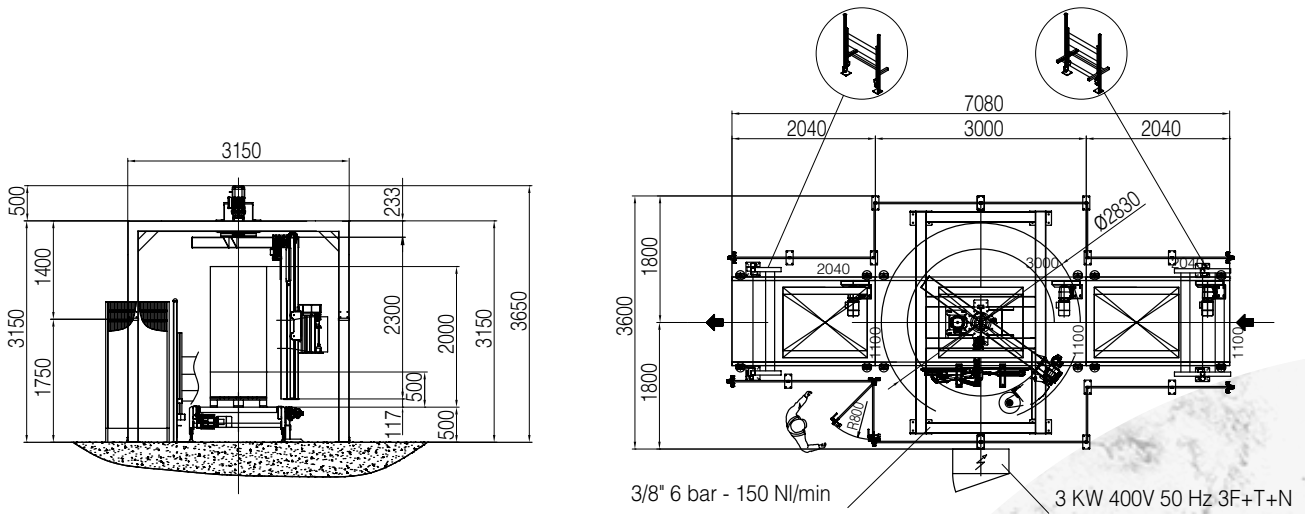

TECHNICAL FEATURES

- Max. load dimensions: 1250 x 1250 mm
- Min. load dimensions: 600 x 800 mm
- STD Wrapping height: 2100 mm
- Max. Rotation speed:
LS: 25 rpm
HS: 30 rpm
HD: 32 rpm
- Working height: 500 mm
- Total installed power:
LS: 3,5 kW
HS: 4,5 kW
HD: 5 kW
- Power supply: 400 V-50 Hz – 3PH+N+G
- Machine protection: IP54
- Operating pressure: 6 bar
- Various optional features available

CARACTERISTIQUES TECHNIQUES

- Dimensions charge max: 1250 x 1250 mm
- Dimensions charge min: 600 x 800 mm
- Hauteur de banderolage STD: 2100 mm
- Vitesse de rotation max
LS: 25 t/min.
HS: 30 t/min.
HD: 32 t/min.
- Hauteur de travail: 500 mm
- Puissance totale installée : LS: 3,5 kW
HS: 4,5 kW
HD: 5 kW
- Tension alimentation: 400V-50 Hz – 3F+N+T
- Protection de la machine: IP 54
- Pression de travail: 6 bar
- Différentes options disponibles

The directions provided are not binding – Les indications fournies ne sont pas contraignantes

